

SAFE-O-TRONIC® *access*  
Electronic Identification and Locking System



Next level *access*

SAFE-O-TRONIC® LS Furniture Locking System



# Next level

A wide range of flexible options for organization and use on cabinets and doors makes managing access even more efficient in any commercial property. You will be astonished how easily different user groups can be managed and how you can re-optimize your locking system at any time as requirements change.

*access*





# SAFE-O-TRONIC®

Electronic Identification and Locking System

SAFE-O-TRONIC® access combines PIN code and RFID technology in a unique way setting new global standards in safeguarding and organizing cabinets, safe-deposit boxes, lockers and furniture. Door solutions can also be integrated. Thanks to the inclusion of emerging NFC technology, managing access is even possible using mobile phones.

# access



## Keyless control

Whether lockers, lock boxes, office or other storage furniture are involved, SAFE-O-TRONIC® *access* replaces customary cylinder and combination locks with electronic locking convenience, making time-consuming key management a thing of the past. Discover the organizational benefits and cost savings for your application. The appealing design adapts perfectly to your interior style.



# Best practice on a new scale



## Advanced cabinet locking device

With its sleek format and wireless design SAFE-O-TRONIC® access locks make the management of electronic locking systems easier and more convenient than ever.

For more than a decade SAFE-O-TRONIC® has been the leading brand for innovative electronic locking devices utilizing RFID technology for cabinets and safe-deposit boxes. Similar to the two successful brands SAFE-O-MAT® and SAFE-O-PIN®, SAFE-O-TRONIC® locks have proven their worth on many thousands of cabinet and room doors around the globe. With the SAFE-O-TRONIC® access product line, the market and innovation leader is setting new standards for intelligent locking devices.

## Unique possibilities:

### • Simple retrofit

It is easy to fit cabinet doors that are prepared for standard cylinders with innovative RFID or PIN code technology.

### • Flexible management

Due to the unique combination of PIN code and contactless RFID technology you can easily organize different security levels and user groups (VIPs, club members, one-day guests or personnel).

### • Easy to operate

Just touch the key fields lightly (capacitive technology) to enter a personal PIN code and/or RFID data carriers (digital keys) are simply presented to the reader for identification.

### • Optimize cabinet capacity

Using convenient time controls, cabinets can be opened or blocked automatically protecting against unauthorized use.

### • Use a mobile phone for locking

Thanks to the new NFC technology, a mobile phone could turn into a locker key (on request).

### • Online organization of offline locking systems

Card-based SAFE-O-TRONIC® CyberNet network offers online convenience without wiring the cabinets.

### • Personalize

Whether it is cabinet numbering or mounting a logo, SAFE-O-TRONIC® access can accommodate your individual design requirements.



**Individualization**

Small identification plates, engraved by laser, with logo or cabinet numbering can be clipped on simply

**Rotary knob for functional reliability**

The rotary knob also provides a manual solution if the cabinet door jams.

**Capacitive keypad for ease of use**

Thanks to capacitive technology just lightly touching the key fields is enough to operate the lock via the PIN pad. The sealed keypad does not wear and also makes use in wet rooms and hygiene sensitive areas problem-free.

**Convenient user guidance**

via LED strip and by means of an acoustic signal

**Intuitive operation**

Simple operation due to use of familiar mobile phone symbols.

**Intelligent battery management**

Even if the battery is low, a cabinet can be opened – but not locked. Using a special tool, the battery can be changed quickly and easily on the outside of the compartment door.

**Reader for RFID-technology**

Simply hold the RFID card in front of the reader.

# Simple replacement of standard cylinder cam locks



## Very easy to fit and retrofit

Cabinet doors that have been prepared for customary standard cylinders cam locks can easily be equipped with SAFE-O-TRONIC® access without time-consuming refinishing.



## Position – screw on - finished!

The electronic locking device that is fitted with a cam lock fits the customary standard punched hole and must only be fastened by an additional screw.



## You are free to choose the mounting direction

SAFE-O-TRONIC® access can be fitted in four different mounting directions depending on your requirement and the type of cabinet.



Examples for different mounting directions



## MOUNTING DIRECTIONS



A



B



C



D

# Perfect fit for every cabinet door



The slim SAFE-O-TRONIC® LS design locks can be used for right-hand and left-hand cabinet doors made from all customary materials and is also ideally suitable for specially shaped cabinet doors.



Example:  
Cabinet doors that curve outwards



Example:  
Frame and panel doors



Example:  
Right-hand and left-hand cabinet doors

**DIMENSIONS**

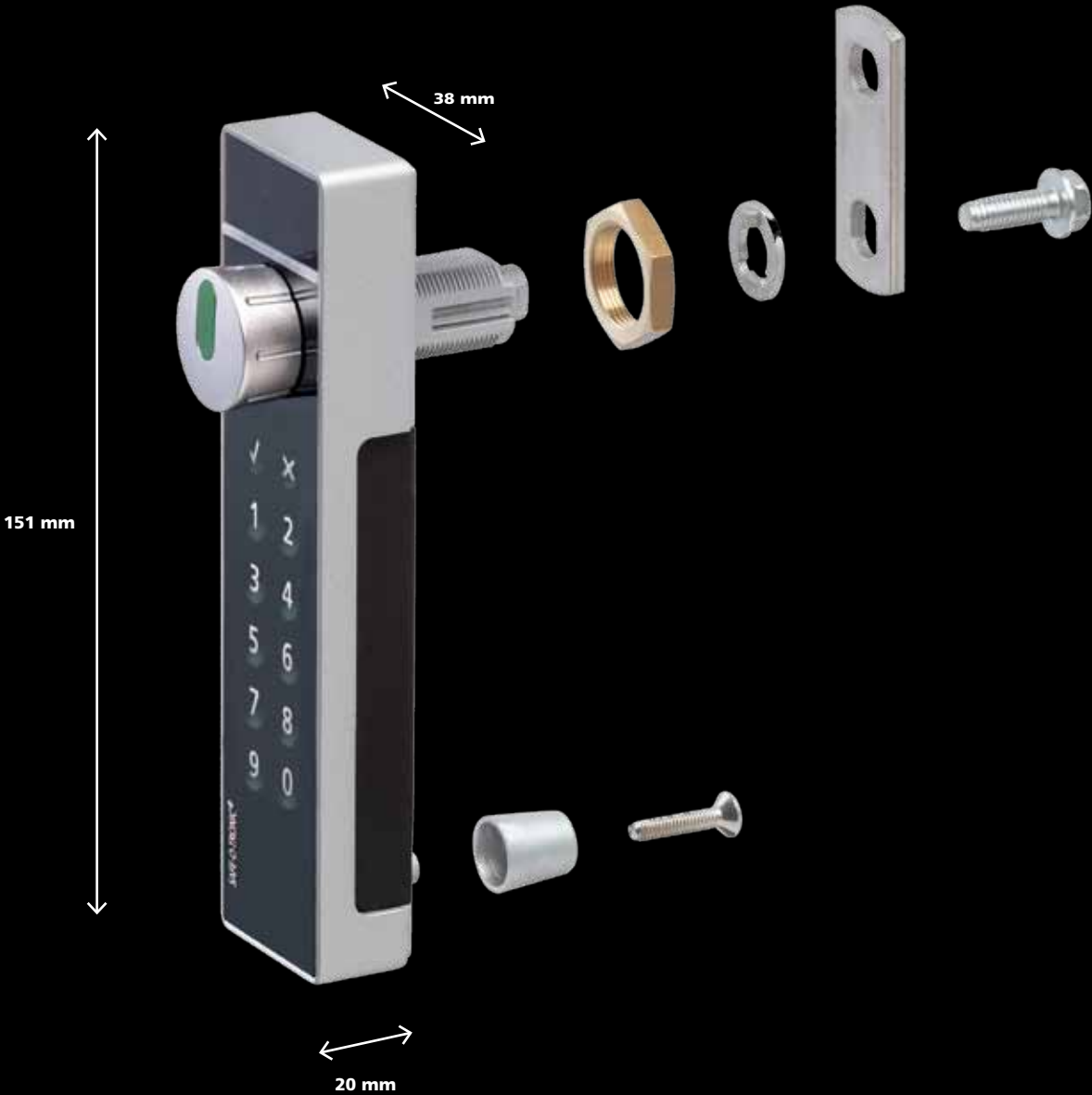

# Keyless Identification



## Keyless - via PIN code

The personal PIN code can be entered easily by touching the key fields lightly. Programming of the locking system with master codes is also available as a time-saving option using a RFID card.



## Contactless - via RFID card

It is enough to hold carrier digital key in front of the reader by using an RFID data carrier (e.g. card, bracelet or key ring). All RFID technologies in accordance with ISO 14443 A (e.g. MIFARE) are available.



## Trendsetting - via mobile phone

Modern mobile phones with NFC technology can optionally be used as a "key".

Overview of the identification possibilities				
Identification	SAFE-O-TRONIC® access			
	LS 100	LS 200	LS 300	LS 400
User				
PIN-Code	•	•		•
RFID-Card			•	•
NFC (on request)			•	•
Master				
PIN-Code	•	•		•
RFID-Card		•	•	•

## PRODUCT LINE

### SAFE-O-TRONIC® LS 100

PIN code  
cabinet locking device



### SAFE-O-TRONIC® LS 200

PIN code cabinet  
locking device with  
RFID programming  
and RFID master code  
function



(o)

### SAFE-O-TRONIC® LS 300

RFID/NFC cabinet  
locking device



(o)

### SAFE-O-TRONIC® LS 400

Combined  
RFID/NFC and  
PIN code cabinet  
locking device



(o)

# Flexible organization possibilities



## Time-saving programming

Using System Keys you can program your locking system in no time at all.

## Quickly recognize vacant/occupied cabinets

Vacant or occupied cabinets can be recognized by the position of the green display marker. Use of the optional square rotary knob amplifies this effect even more.

## Designed for accessibility

Special rotary knobs are available to accommodate users with disabilities – compliant with ADA (Americans with Disabilities Act) guidelines.

## Flexible organization

Even when access plans need to change, you will maintain a flexible grip on the widest range of user groups: for example, one-day guests can lock using the PIN code, club members use their RFID identity card and employees use their staff card. Combined use via RFID card and an additional PIN code is available for added security requirements.

## Put a time limit on access

Time limits can be applied to use and time zones can be set up quickly and easily using the integrated clock. For example, to protect against unwanted “squatters” you can program the locking devices so your cabinets open automatically at a time of your choice (e.g. automatic night opening) or are blocked for certain periods. In this way, you can always optimize your cabinet capacity.

## Convenient monitoring

For monitoring purposes, the locking procedures can be accurately logged, printed, and evaluated.

## Controlled opening

In addition to the conventional emergency key access scheme, locks can be programmed to require special keys to relock when they have been opened by staff. In this way, you can increase security for your guests and protect your staff against baseless suspicion.

Overview Organisation Possibilities				
Organisation	SAFE-O-TRONIC® access			
	LS 100	LS 200	LS 300	LS 400
User				
PIN	•	•		•
RFID			•	•
PIN or RFID				•
PIN + RFID				•
NFC (on request)			•	•
Master				
Master 1 PIN-Code	•	•		•
Master 2 PIN-Code	•	•		•
Master 1 RFID-Card		•	•	•
Master 2 RFID-Card		•	•	•
Programming				
Via System Keys		•	•	•
Via programming (Communicator)			•	•
Time functions				
Time limitation		•	•	•
Monitoring				
Locking logs		•	•	•

## KNOB ALTERNATIVES

**SAFE-O-TRONIC®**  
with round rotary knob



Vacant/occupied displayed  
by green marking on the knob

**SAFE-O-TRONIC®**  
with square rotary knob



Vacant/occupied displayed  
by green marking on the knob  
and horizontal or vertical position of the knob

# Wide range of applications



**SAFE-O-TRONIC® access offers a wealth of intelligent possibilities for efficient organization of the storage and access management in all commercial properties.**

## **Sport & leisure time**

SAFE-O-TRONIC® access provides a high degree of efficiency in the organization of lockers and safe-deposit systems in modern leisure facilities with their varied user types. Perfectly integrated into your guest management system, SAFE-O-TRONIC® access you can carry out customer-friendly and resource-saving schemes for storage PIN, RFID or NFC. Handle one-day guests or regular guests, event visitors or club members, associations or schools, children, juveniles, senior citizens or people with disabilities, with the same solution. The capacitive keypad facilitates use in wet rooms such as swimming pools and sauna areas.

## **Clinics & hospitals**

Controlled staff access to changing room lockers and safe boxes for valuables, internal postal boxes, medicine and supply carts, pharmaceutical, laboratory and document cabinets is just as important in clinics and

hospitals as the keyless patient locking of cabinets, safe boxes for valuables and clinic bedside tables. Due to its compact design SAFE-O-TRONIC® access fits on nearly every item of storage furniture. Identification systems for employees and patients can also be integrated.

## **Industry & administration**

With SAFE-O-TRONIC® access time-consuming key management for staff lockers, filing and office cabinets and postal boxes in industrial and administration properties becomes a thing of the past. It is remarkably simple and cost-effective when used to replace standard cylinder cam locks.

A PIN code or employee identification card is enough for controlled use that is limitable by time. Thus, in the case of multi-shift operations, one cabinet can be used by several employees during each day. This results in the highly efficient organization of the storage of work and street clothing (in areas sensitive to hygiene).

## **Schools & universities**

The student or pupil identification card has already taken on the key function in numerous universities, colleges and other educational establishments. SAFE-O-TRONIC® access provides storage management advantages.

Convenient time control functions prevent unwanted “squatters” in public shared lockers and dynamic management for classroom, laboratory, equipment, file storage and more.

## **Libraries & museums**

Bag lockers in libraries and museums provide important protection and prevent theft. In addition to keyless use (Identification card for registered users or PIN code for guests) SAFE-O-TRONIC® access offers intelligent solutions to protect against locker “squatters” (by means of time-controlled opening or locking).

## **Retail industry**

SAFE-O-TRONIC® access provides for time-saving, keyless use of bag lockers at retailers as protection against the theft of goods. At shopping centers, a convenient storage service for shopping bags caters for “unburdened” shopping pleasure and increases the length of stay, providing enhanced sales opportunities for the operator. When it comes to the organization of staff lockers SAFE-O-TRONIC® access helps to enlarge the sales area by reducing cabinet capacities.



## APPLICATION AREAS



Sport & leisure time



Clinics & hospitals



Industry & administration



Schools & universities



Libraries & museums



Retail industry

# The ideal solution for every demand



**Whether it is costs, convenience, security or design, SAFE-O-TRONIC® access qualifies as an excellent investment decision.**

## **Arguments for the cost-conscious**

- Simple replacement of classic cam locks and universal use on nearly every cabinet door saves time and costs during installation.
- Programming and commissioning is dealt with in a cost-effective way with the use of System Keys.
- Flexibility that supports organizational changes minimizes follow-up costs while maximizing the systems usefulness.
- Various functions to protect against unauthorized users optimize existing cabinet capacity.
- The long-term power supply using standard batteries and as does the capacitive keypad (not subject to wear) minimizes operating costs.

## **Arguments for the convenience-conscious**

Operating comfort comes high on the list of priorities where SAFE-O-TRONIC® access is concerned:

- Vacant/occupied is displayed to help find a vacant cabinet quickly.
- Convenient rotary knob for easy accessibility for all users.
- Sensitive touch keys assure precise and reliable entry of the code.
- Contactless alarm sensor for fast identification via RFID card.
- Intuitive user guidance with visual and acoustic acknowledgement.
- Simple battery replacement on the outside of the cabinet door.
- Online convenience for offline RFID locking systems due to card-based network (SAFE-O-TRONIC® CyberNet).

## **Arguments for the security-conscious**

- Due to the innovative combination of the PIN, RFID and NFC identification options, SAFE-O-TRONIC® access increases security for both users and operators. Security is also guaranteed following the loss of a card.
- A cut-off time provides protection against unauthorized attempts at opening.

- If „worst comes to the worst“ the locking audit trails can be read out for monitoring purposes and evaluated.
- In addition to investigating a theft, the monitoring of emergency openings protects users and operators from baseless suspicion.
- Service concepts tailored to your individual requirements optimize the operational security of your locking system in every project phase.

## **Arguments for the design-conscious**

- The clean, intuitive and function-oriented design of the SAFE-O-TRONIC® access cabinet locking devices adapts perfectly to the style of most furniture.
- Multiple installation options support varied designs for locking and location.
- The design communicates high-quality and precise construction in keeping with our company philosophy that recognizes the demand for durable and reliable products.



For the cost-conscious



For the security-conscious



For the convenience-conscious



For the design-conscious

# Technical Data



SAFE-O-TRONIC® access	
Operating modes	Free choice of cabinet / fixed cabinet allocation
Indicators	2 x LED green: authorized 2 x LED red: not authorized
Acoustic signal	Signal generator - beep
Battery	Battery pack: 3 premium alkaline cells (AAA)
Battery service life	3 years based on 30 lock cycles per day
Temperature ranges	
Function	0° bis +60°C
Storage	-15° bis +60°C (battery service life limited at ≤ 0°C)
Relative humidity	10 - 90% non-condensing
Protection class acc. to DIN EN 60529	IP 43
Weight	Approx. 300g / 10 oz
Housing dimensions incl. rotary knob (H x W x D)	151mm x 38mm x 33mm 5 15/16" x 1 1/2" x 1 5/16"
Colour of housing frame	Similar to RAL 9006 (white aluminium)
Colour of control panel	Black/white as an option

SAFE-O-TRONIC® access				
	LS 100	LS 200	LS 300	LS 400
<b>Identification</b>				
PIN (min. 4 digits)	•	•		•
RFID (MIFARE, ISO 14443 A)			•	•
NFC (on request)			•	•
<b>Accessories</b>				
SystemKey-Set		•	•	•
TestKey		•	•	•
USB Reader		•	•	•
Lock Manager Software		•	•	•
Communicator			•	•
Offline terminals (for surface fitting or flush-mounted fitting)			•	•
Info terminal (for displaying the cabinet number for „free choice of cabinet“)			•	•
<b>Miscellaneous</b>				
Contactless alarm sensor			•	•
Cut-off time against unauthorized attempts at opening	•	•		•
Locking log memory for 450 entries		•	•	•

## ADAPTIONS



Adaption with locking cam

Adaption with espagnolette

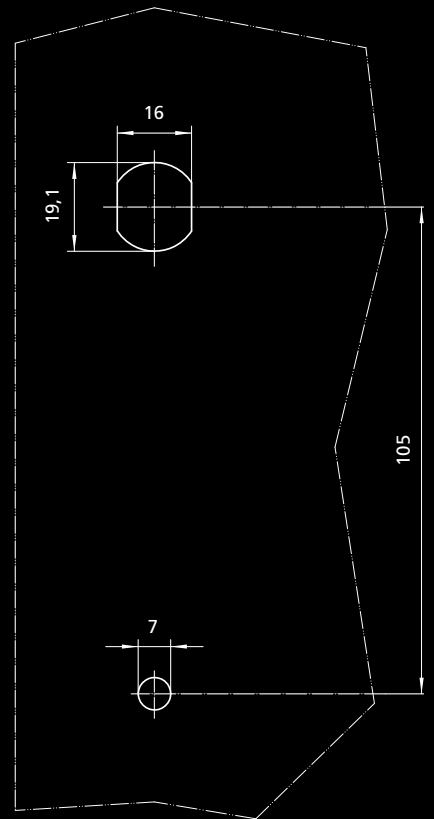
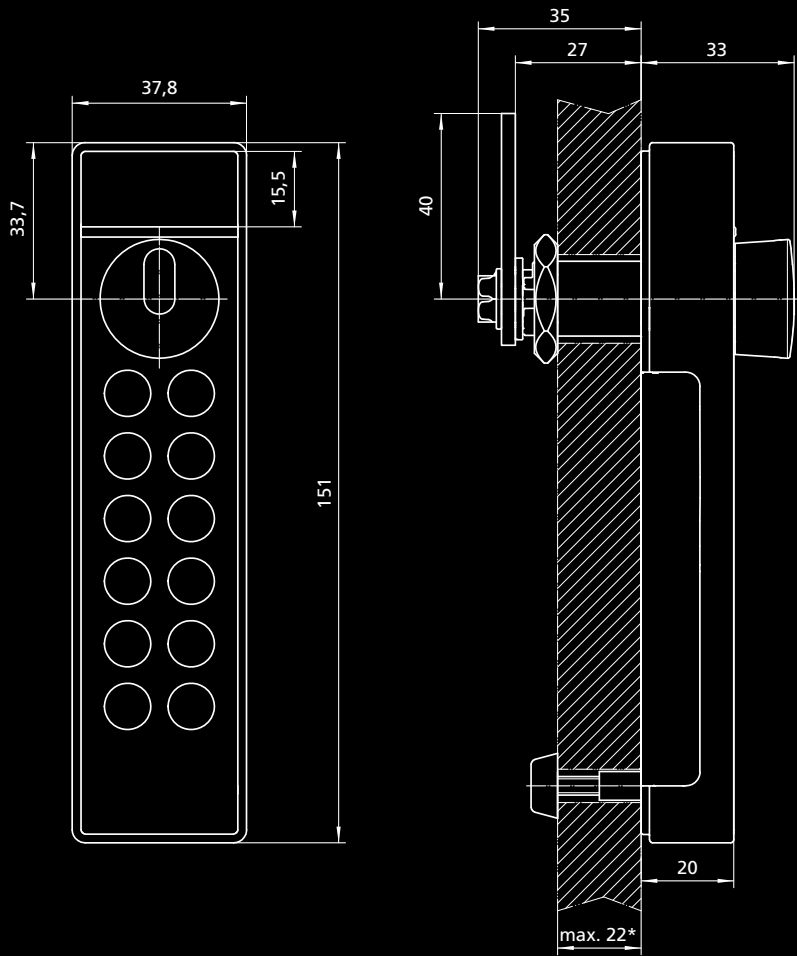

**\*When using special mounting material**

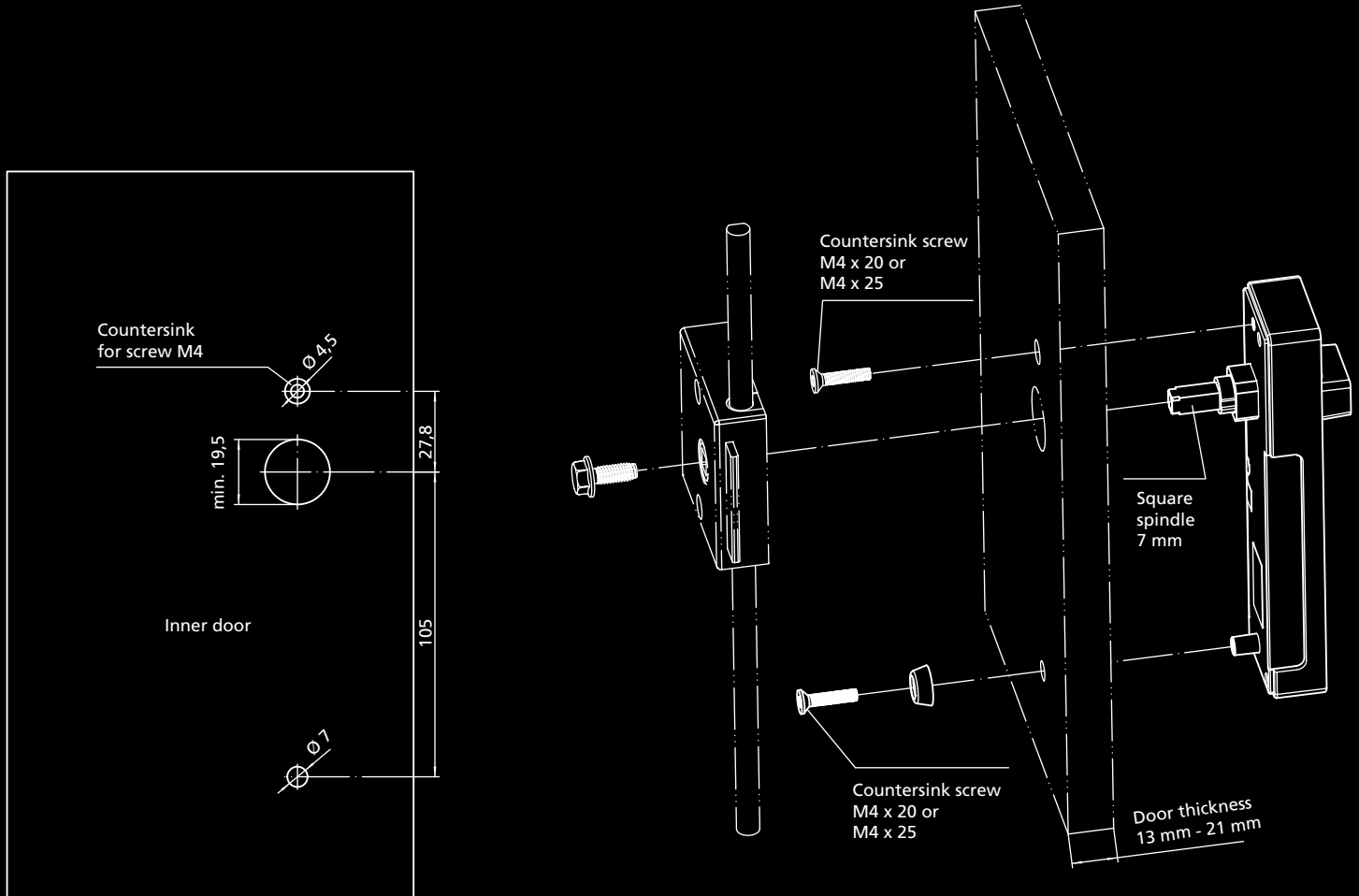

Adaption with espagnolette

# Standard solution for cabinets and doors



**SAFE-O-TRONIC® access offers you an integrated organization solution for your door and cabinet locking systems. This makes the control and administration of locking and access rights particularly easy and efficient.**



## **Flexible organization of cabinets and doors**

Integrated in an electronic door fitting, the same identification possibilities that are available for your cabinet systems allowing for flexibility in combination (PIN code, RFID and NFC) are available to you for the organization of your door locking systems.

## **Efficient system management**

You can program and manage your cabinet and door locking systems conveniently using standard software. Even in the case of organizational changes you always have all the current relevant data for your locking systems under control which saves costs and avoids time-consuming reconciliations and multiple entries.

## **Simple integration into data systems**

Thanks to its open system architecture and wide range of components SAFE-O-TRONIC® access can always integrate of your cabinet and door locking systems with other data systems (access control, staff time reporting, cashless accounting or guest management).



**ROOM EXAMPLES**

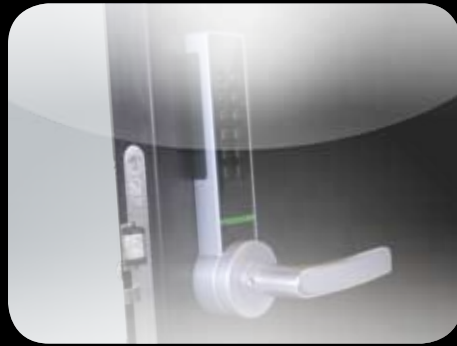

# Service



The SAFE-O-TRONIC® access cabinet locking devices stand out due to simple handling, a high degree of operating safety and user friendliness, as well as a minimum amount of maintenance. We are also able to offer you a comprehensive range of services to plan and optimize your system capabilities during every phase of your project. Our competent service team would be delighted to consult and develop your custom application. Here is an overview of our range of services offered:

Overview of services
<b>Consulting</b>
Management consultation
Project planning
Technical consultation on site
Lockerd door sampling
Support during integration into data system
<b>Coding service provided by the factory</b>
Coding of the locking devices in the factory
Coding of the RFID data carriers in the factory
<b>Individualisation</b>
Numbering (for cabinets only)
Marking with a logo
Customised adaptations

## On-site service Assembly /

- Installation
- Modification of existing doors
- Comissioning
- Configuration
- On-site coding service for the locking devices
- On-site coding service for the RFID data carriers

## Self-help training

- Partner training
- On-site customer training
- Customer training in the factory

## After sales service

- Phone support during business hours
- Service hotline
- Remote maintenance
- Update service for Lock Manager software
- Battery service
- Service for spare parts and consumables

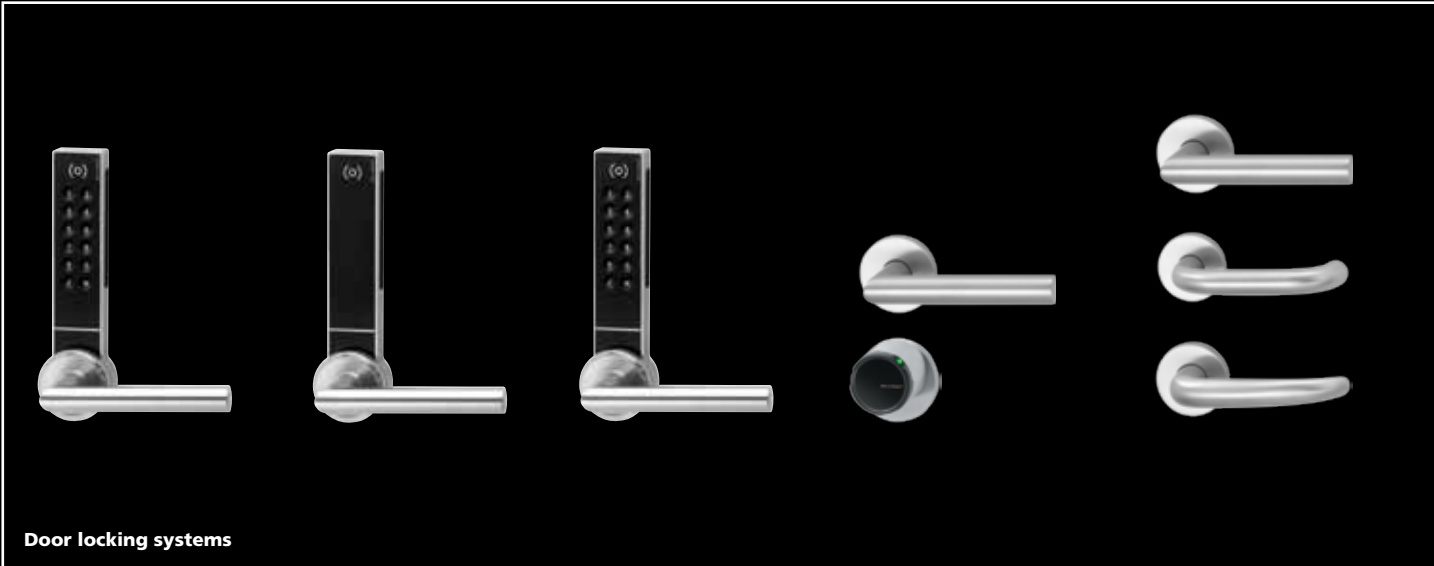

Door locking systems



Furniture locking systems

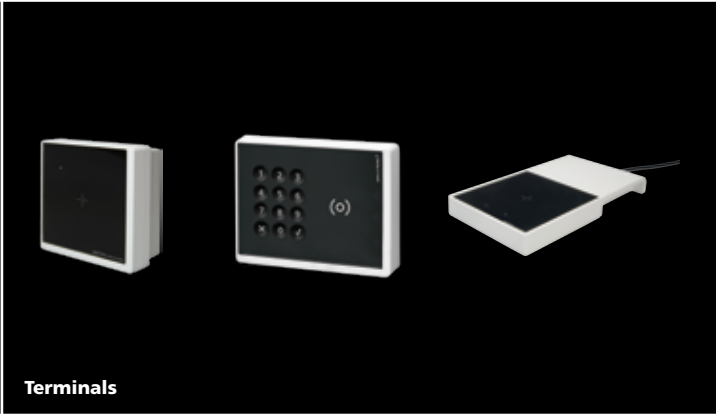

Terminals

# Next level access





Promoted by the Bundesministerium für  
Wirtschaft und Technologie (German Federal  
Ministry of Economic Affairs and Technology)  
on account of a resolution passed by the  
Deutscher Bundestag (German Bundestag)



**CEMAG-GROUPE**

7, rue Gaston Prétot – Parc d'Activités des Courts Cantons  
25200 Montbéliard – France

Tél. : +33 (0)3 81 32 19 95 – Fax : +33 (0)3 81 94 34 12

Mobile : +33 (0)6 09 59 13 49

Mail : [g.chauvez@cemag-groupe.com](mailto:g.chauvez@cemag-groupe.com)

[www.cemag-groupe.com](http://www.cemag-groupe.com)